

**CITY OF FARMINGTON HILLS  
BUILDING DIVISION  
31555 W. Eleven Mile Road, Farmington Hills, MI 48336  
248-871-2450**

**DUAL WATER METER REQUIREMENTS (EFFECTIVE JULY 1, 2018)**

1. A Farmington Hills Plumbing Permit must be presented to the Oakland County Water Resources Commissioner's Office (WRC) when making application for the County Dual Meter Permit. The \$85.00 plumbing permit fee includes the required final inspection by the City of Farmington Hills (see handout explaining the procedure for requesting inspections).
2. WRC will issue a water meter after the dual meter permit is obtained. The permit and meter can be obtained in person or by mail (copy of the Farmington Hills plumbing permit must be included with permit application to WRC) at the following location: Oakland County Water Resources Commissioner's Office, One Public Works Drive, Building 95W, Waterford, MI 48328 (248-858-0958).
3. Minimum meter size for the outside maintenance use meter (m-2) shall be 1". The cost for a 1" meter is \$400.00 which includes the exterior meter readout installation charge.
4. The Oakland County dual meter permit charge is \$50.00.
5. The existing water meter shall be re-installed as M-1 by the permit holder.
6. Both meters shall be fully independent – requiring a full opening gate or ball valve before and after each meter (see diagram).
7. Both meters shall have an electrical jumper cable (#4 minimum) installed for ground continuity. (See diagram).
8. Owner/Plumber to assure that the outside readout cable can be accommodated for both meters. This may require the Owner/Plumber to install a conduit through the building wall.
9. New homes may make application and pay for their DMS meter along with their normal water permit charges at WRC at the location indicated in #2 above. After the permit is issued, the permit holder may obtain their meters at the location indicated in #2 above. A copy of the City plumbing permit is not required for new homes.
10. It is the permit holder's responsibility to install the water meter(s) and contact the WRC Water Maintenance Unit to have the meter installation inspected and the remote reader installed. Access to building must be provided for final inspection.

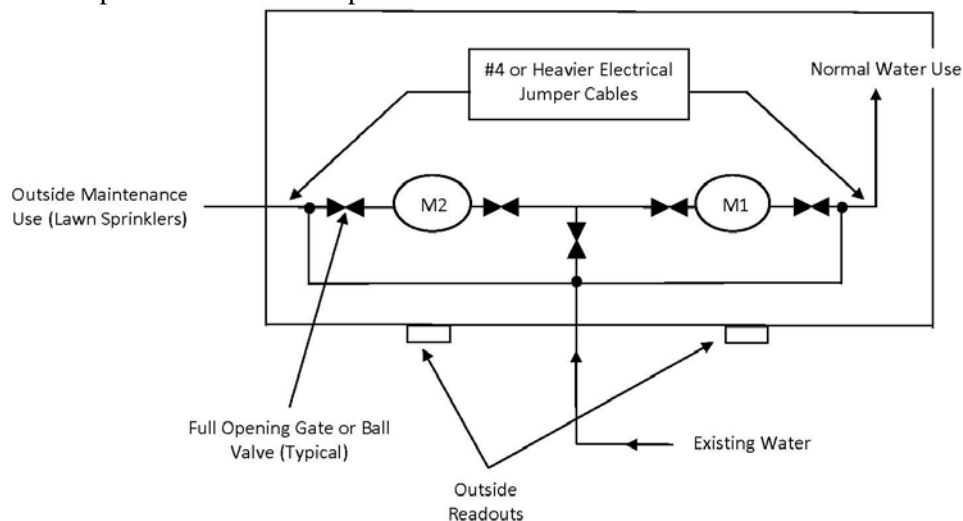

## DUAL METERS:

This program allows a property owner use of a second water meter connected for outside use only. At the option of a property owner, this second or dual meter can be installed to meter water that is directed exclusively to a sprinkler system or outside spigot/connection such as to a swimming pool and will not enter a sanitary sewer. The installation of a dual meter at the home would allow the sewage rate to be billed only on that amount of water that enters the sewer system through the home. Sewage fees would not be charged on the water that flows through the second meter for outside use. The fixed costs are the 1" water meter and permit charges (\$535.00). Plumbing charges may vary depending upon the complexity of the changes required to install the second meter.

Any water and sewer customer can take advantage of this program. The customer, however, should evaluate individual circumstances based on use to calculate cost effectiveness. We have included calculation factors to help determine potential cost savings.

### 2018/2019 RATE YEAR

#### TO DETERMINE POSSIBLE SAVINGS WITH A DUAL WATER METER

1. Accumulate the total annual water usage (will be shown in 100 cubic feet on the bills) shown on four consecutive bills (one-year period).  
Total Annual Usage \_\_\_\_\_ 100 cubic ft.
2. Determine which bill best represents the winter months when sprinklers are not used.  
Record the usage for that bill \_\_\_\_\_ 100 cubic ft.
3. Multiply this one winter bill amount (#2) by 4  
Total Sewer Portion \_\_\_\_\_ 100 cubic ft.
4. Subtract the Total Sewer Portion (#3) from the Total Annual Usage (#1)  
\_\_\_\_\_ 100 cubic ft.
5. Multiply #4 by 3.761 (2018/2019 rate) \$ \_\_\_\_\_

This is the estimated amount that would be saved annually by installing a dual meter.

For further information please contact the Operation & Maintenance Division of the Oakland County Water Resources Commissioner's Office at (248) 858-0958 or the City's Department of Public Services at (248) 871-2530.

# Welcome

## Oakland County Service Center

1200 N. Telegraph Road • Pontiac, MI  
(248) 858-1000 • OakGov.com

9

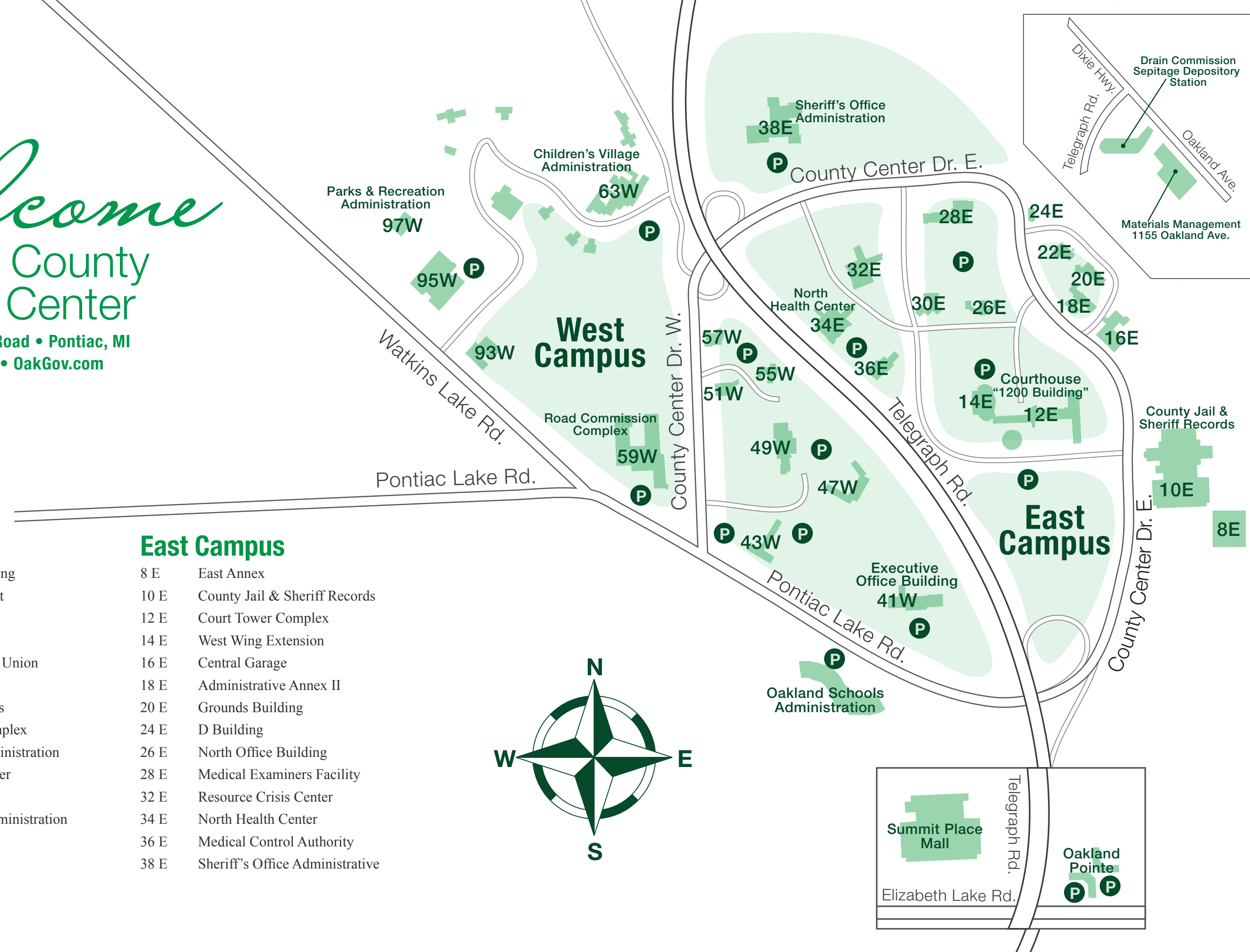

### West Campus

- 41 W Executive Office Building
- 43 W Oakland County Market
- 47 W Homeland Security
- 49 W Administrative Annex I
- 51 W Oakland County Credit Union
- 55 W Easter Seals Society
- 57 W Sheriff's Patrol Services
- 59 W Road Commission Complex
- 63 W Children's Village Administration
- 93 W US Army Reserve Center
- 95 W Public Works Building
- 97 W Parks & Recreation Administration

### East Campus

- 8 E East Annex
- 10 E County Jail & Sheriff Records
- 12 E Court Tower Complex
- 14 E West Wing Extension
- 16 E Central Garage
- 18 E Administrative Annex II
- 20 E Grounds Building
- 24 E D Building
- 26 E North Office Building
- 28 E Medical Examiners Facility
- 32 E Resource Crisis Center
- 34 E North Health Center
- 36 E Medical Control Authority
- 38 E Sheriff's Office Administrative

